

LIMITED TENDER NOTICE

Ref No.: SU/REG/Admn/F-2/24(31)/2018/Vol-II/1591

Date: 20.12.18

Limited Tender Notice for Fabrication/Supply of Furniture's and fixing of linoleum at dept. of Political Science, Sikkim University.

Bids are invited by Sikkim University from **empanelled and un-empanelled contractors of the university** for, **Fabrication/Supply of Furniture's, Supply and fixing of linoleum at dept. of Political Science Sikkim University** as per the terms and conditions below:

Terms and Conditions

1. The bid should be submitted in compliance to the NIT. The terms and conditions of the empanelment would also be applicable and binding to all contractors in addition to the terms and conditions for the tender.
2. EMD amounting ₹ 3750.00 have to be submitted in the form of NEFT of any Scheduled /Nationalised Bank favouring 'Sikkim University, payable at Gangtok to the account detail below: (Not required for Impaneled contractors)

• Account Holder's Name	:	Sikkim University
• Account No	:	112010100231541
• Account Type	:	Savings Account
• IFS CODE	:	UTIB0000112
• Branch	:	Gangtok [SK]
• Bank Name	:	AXIS Bank

3. The details for the work has been enclosed as Annexure-I. The bidder is to submit the necessary % above/below/at par for the work based on the details and estimate in the Quote Performa given at Annexure – II (Financial Bid). The Financial Bid (Annexure-II) is to be submitted in official letter head of the bidder.
4. The work is to be completed in all respect within 30 days from the date of award of the work order. A penalty of Rs. 500 per day, maximum to the limit of 10% of the work value would be imposed to the successful bidder for delay beyond the mentioned date of completion of the work.
5. The work is to be completed in all respect to the satisfaction of the University. Defect liability period shall be 6 months from the date of completion of the work. The bidders may contact the Engineering Cell on 9547116279 for any query related to the work.
6. The rate should be quoted including all costs such as labour charges, materials, transportation, GST etc. No other charges shall be entertained under any circumstances.
7. No interest shall be paid by the university on any deposits held as security against the work.
8. Full and final payment shall be made only after completion of the entire work & award of completion certificate by authority concerned. No advance /part payment shall be made. 5% of final billing amount shall be withheld as performance security and shall be returned after completion of the liability period along with EMD of successful bidder.
9. Construction material should be of reputed make & quality to the satisfaction of the university authority.
10. The bid is to be submitted in a sealed envelope in the Office of the Executive Engineer, Sikkim University during

office hours on or before **31st December 2018**. The sealed envelope should clearly mention the name of the work and the bidders address.

11. No bids received beyond the last date of submission shall be accepted by the University.
12. Arbitration of all dispute related to the procurement, delivery and the services of the goods would be within Gangtok jurisdiction, Sikkim.
13. The Registrar, Sikkim University, has the power to reject any bid or extend the date of receipt of application without citing any reasons. The decision of the Registrar, Sikkim University will be final and binding to all empanelled contractors.

**Sd/-
Registrar**

COMPANY PROFILE

Supplier's Ref. No......

Construction of Furniture's, Supply and fixing of linoleum at dept. of Political Science, Sikkim University

No.:..... **dated:**.....

FOLLOWING DETAILS ARE TO BE FURNISHED BY THE BIDDING FIRM

1. Name of the Firm:
2. Address of the Firm:
3. Contact no:
4. Email address:
5. Registration details:
6. Permanent Account Number:
7. GST registration details:

Declaration:

I/We hereby declare that I/We have read & understood all the terms & conditions mentioned in the E-tender notice the quotations and I/We undertake myself/ourselves to abide by them.

I/We further, declare that all the information given above is true.

Name:

Designation:

[Official Seal with authorised signature]

Place:

Date:

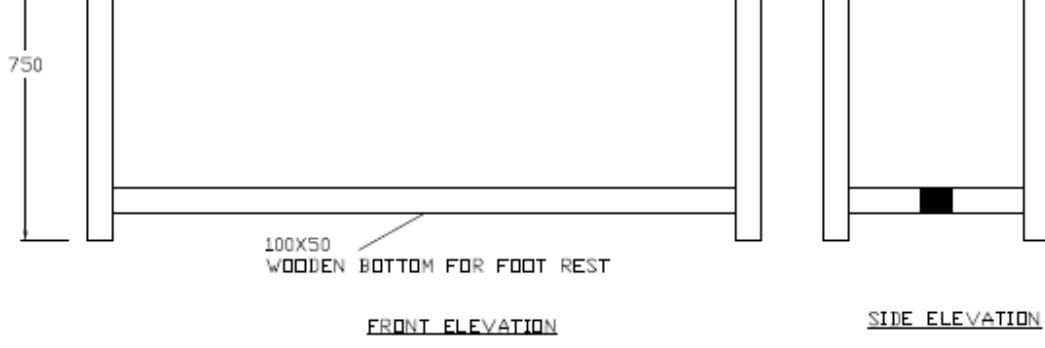

ALL DIMENSIONS IN mm UNLESS SPECIFIED OTHERWISE

COMPUTER TABLE

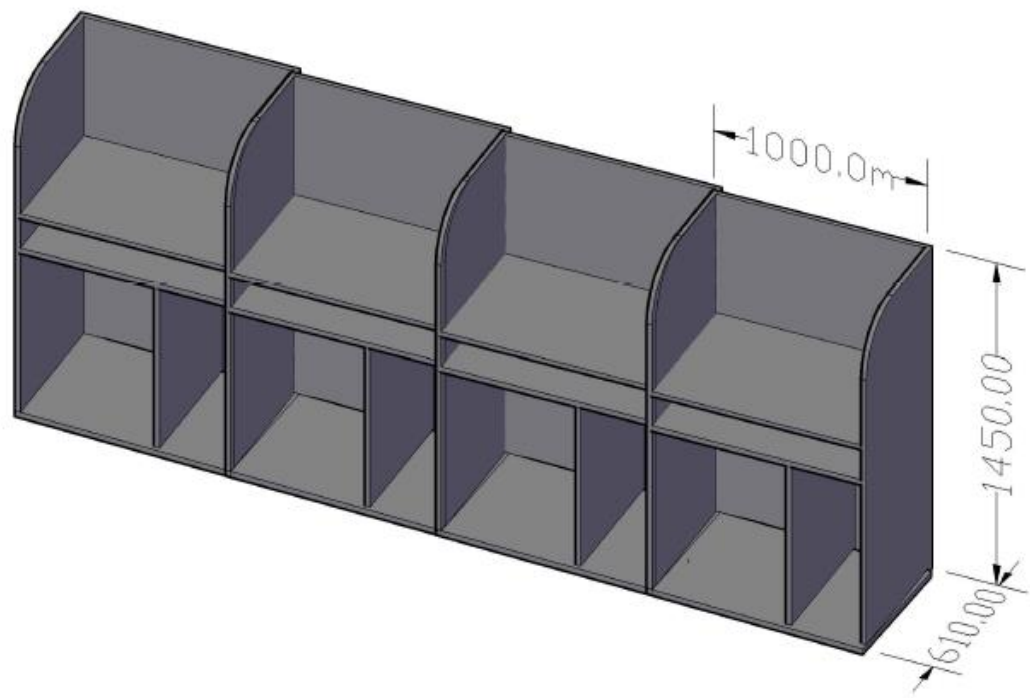

Drawings 2:

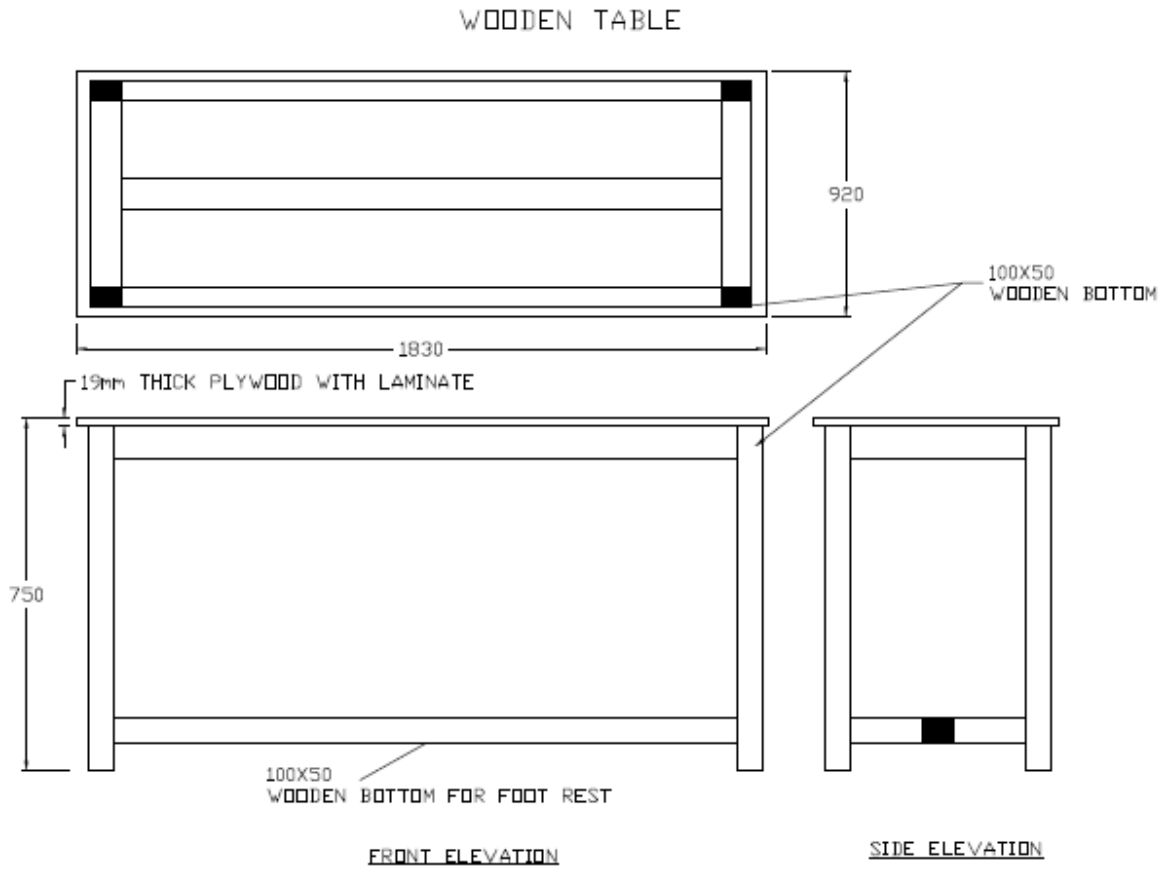

ALL DIMENSIONS IN mm UNLESS SPECIFIED OTHERWISE

Details of work

Sl.no	Particulars of works	No	Measurement			Qty	Unit	Rate	Amount	Remarks
			L	B	H					
1	Construction of contineous wooden computer table including space for key board and CPU with best quality marine plywood 19mm thick with lamination over the top and sides including space for key board all complete as per engineer incharge.									Rate analysis
		1	12.250	-	0.610	7.473	Sq.m	11388.42	85100.00	
2	Construction of wooden table with 3/2 buttoms and marine plywood 19mm thick with lamination over the top and including priming painting in frames all complete as per engineer incharge. Size (1.82 X0.920)m									Rate analysis
		3	-	-	-	3.000	No	11600.00	34800.00	
3	Providing and laying 1.5mm thick linoleum after properly cleaning the surface with best quality adhivise all complete as per engineer incharge.									Rate analysis
	Faculty Room no-205	1	2.750	4.400	-	12.100	Sq.m			
	206	1	2.750	4.400	-	12.100	Sq.m			

	209	1	5.250	2.500	-	13.125	Sq.m		
	208	1	3.700	5.650	-	20.905	Sq.m		
	207	1	3.700	5.650	-	20.905	Sq.m		
	212	1	2.900	3.620	-	10.498	Sq.m		
	213	1	4.600	4.100	-	18.860	Sq.m		
	214	1	3.850	4.100	-	15.785	Sq.m		
					Total	124.278		500.00	62139

***Inclusive of all taxes.**

Total ₹ 182,039.00
Grand Total ₹ 182,039.00

Rupees (One lakh eighty two thousand and thirty nine) only

Annexure – II (Financial Bid)

(To be submitted in official letterhead of the contractor)

Estimated cost: Rs. 182,039.00 (Rupees(One lakh eighty two thousand and thirty nine)only
) only

(a) Quoted % above or below : _____ % (Above / Below / At par)

(b) Amount for the work based on the % quoted in (a) : Rs. _____

(c) Amount in words : RUPEES _____

(d) Additional Taxes if any on (b) : _____ %

(e) Tax amount if any: Rs. _____

(f) Final Amount for the work (b + e) : Rs. _____

(g) Final Amount in words: RUPEES _____

Name:

Sign and Seal:

Date: